

PROFESSIONAL DIGITAL TWO-WAY RADIO

MOTOTRBO™ MOBILE



CM200d NUMERIC DISPLAY MOBILE

CM300d ALPHANUMERIC DISPLAY MOBILE

XPR 2500 ALPHANUMERIC DISPLAY MOBILE

INSTALLATION GUIDE



Foreword

This manual is intended for use by experienced technicians familiar with similar types of equipment. Specifically, it contains installation information required for the CM200d/CM300d and XPR 2500 Mobile Radios.

For information related to the service of the CM200d/CM300d and XPR 2500 Mobile Radios, refer to *Related Publications on page v* for the list of applicable manuals available separately.

Product Safety and RF Exposure Compliance

See [Installation Requirements for Compliance with Radio Frequency \(RF\) Energy Exposure Safety Standards](#) on page ii.

Manual Revisions

Changes which occur after this manual is printed are described in PMRs (Publication Manual Revisions). These PMRs provide complete replacement pages for all added, changed, and deleted items.

To obtain PMRs, go to:

<https://businessonline.motorolasolutions.com/>

Parts Ordering

See [Appendix A: Replacement Parts Ordering](#) for information on how to obtain replacement parts. For part numbers, refer to the MOTOTRBO CM200d/300d Mobile Basic Service Manual (Motorola publication part number 68009618001) or the MOTOTRBO XPR 2500 Mobile Basic Service Manual (Motorola publication part number 68009620001).

Computer Software Copyrights

The Motorola products described in this manual may include copyrighted Motorola computer programs stored in semiconductor memories or other media. Laws in the United States and other countries preserve for Motorola certain exclusive rights for copyrighted computer programs, including, but not limited to, the exclusive right to copy or reproduce in any form the copyrighted computer program. Accordingly, any copyrighted Motorola computer programs contained in the Motorola products described in this manual may not be copied, reproduced, modified, reverse-engineered, or distributed in any manner without the express written permission of Motorola. Furthermore, the purchase of Motorola products shall not be deemed to grant either directly or by implication, estoppel, or otherwise, any license under the copyrights, patents or patent applications of Motorola, except for the normal non-exclusive license to use that arises by operation of law in the sale of a product.

Document Copyrights

No duplication or distribution of this document or any portion thereof shall take place without the express written permission of Motorola. No part of this manual may be reproduced, distributed, or transmitted in any form or by any means, electronic or mechanical, for any purpose without the express written permission of Motorola.

Disclaimer

The information in this document is carefully examined, and is believed to be entirely reliable. However, no responsibility is assumed for inaccuracies. Furthermore, Motorola reserves the right to make changes to any products herein to improve readability, function, or design. Motorola does not assume any liability arising out of the applications or use of any product or circuit described herein; nor does it cover any license under its patent rights nor the rights of others.

Trademarks

MOTOROLA, MOTO, MOTOROLA SOLUTIONS and the Stylized M logo are trademarks or registered trademarks of Motorola Trademark Holdings, LLC and are used under license. All other trademarks are the property of their respective owners.

© 2013 Motorola Solutions, Inc. All rights reserved.

Installation Requirements for Compliance with Radio Frequency (RF) Energy Exposure Safety Standards

ATTENTION!

This radio is intended for use in occupational/controlled conditions, where users have full knowledge of their exposure and can exercise control over their exposure to meet FCC limits. This radio device is NOT authorized for general population, consumer, or any other use.

To ensure compliance to RF Energy Safety Standards:

- Install only Motorola approved antennas and accessories.
- Be sure that antenna installation is per *“Antenna Installation,”* on page 2-10 of this manual.
- Be sure that Product Safety and RF Safety Booklet enclosed with this radio is available to the end user upon completion of the installation of this radio.

Before using the mobile two-way product, CM200d/CM300d/XPR 2500, read the RF Energy Exposure and Safety guide that ships with the radio which contains important operating instructions for safe usage and RF energy awareness and control for Compliance with applicable Standards and Regulations.



WARNING

For radios installed in vehicles fuelled by liquefied petroleum gas, refer to the (U.S.) National Fire Protection Association standard, NFPA58, for storage, handling, and/or container information.

This radio has a transmitter Time-out Timer that disables the transmitter during a transmission after a pre-defined time period, which by default is set to 60 seconds.



Caution

It is recommended NOT to change the default 60 seconds time period for the Time-out Timer as the radio is intended for intermittent duty cycle operation.

For a list of Motorola-approved antennas and other accessories, visit the following web site, which lists approved accessories for your radio model:

<http://www.motorolasolutions.com/radiosolutions>

Table of Contents

Foreword	i
Product Safety and RF Exposure Compliance	i
Manual Revisions	i
Parts Ordering	i
Computer Software Copyrights	i
Document Copyrights	i
Disclaimer.....	i
Trademarks	i
 Installation Requirements for Compliance with Radio Frequency (RF) Energy Exposure Safety Standards	 ii
 Mobile Radio Model Numbering Scheme	 vi
 Commercial Warranty	 vii
Limited Warranty	vii
MOTOROLA COMMUNICATION PRODUCTS.....	vii
I. What This Warranty Covers and For How Long.....	vii
II. General Provisions	viii
III. State Law Rights	viii
IV. How to Get Warranty Service	viii
V. What This Warranty Does Not Cover.....	viii
VI. Patent and Software Provisions.....	ix
VII. Governing Law.....	ix
 Chapter 1 Introduction	 1-1
1.1 Mobile Radio Description	1-1
1.1.1 Overview	1-1
1.1.2 Dimensions	1-1
1.1.3 Connections on the Back of the Radio	1-3
1.2 Standard Configurations	1-4
1.2.1 Dash Mount Configuration	1-4
 Chapter 2 Installation Details for Standard Configurations	 2-1
2.1 Planning the Installation.....	2-1
2.1.1 Tools Required for Installation	2-1
2.1.2 Installation Example.....	2-1
2.1.3 Wiring Diagrams	2-2
2.2 Radio Mounting.....	2-3
2.2.2 Locking Kit (Optional)	2-6
2.2.2.1 All Radios.....	2-6
2.2.3 DIN Mount.....	2-6
2.2.3.1 To install the frame into the dashboard	2-6
2.2.3.2 To Mount the radio in the frame.....	2-7
2.2.3.3 To Remove the radio from the frame.....	2-8
2.3 Power Cable	2-8
2.4 Ignition Sense Cable.....	2-10
2.5 Antenna Installation	2-10
2.5.1 Selecting an Antenna Site/Location on a Metal Body Vehicle	2-10

2.5.2	Antenna Installation Procedure.....	2-11
2.5.3	Antenna Connection	2-12
2.6	Microphone Hang-Up Clip	2-13
2.6.1	Standard Hang-Up Clip.....	2-13
2.7	Completing the Installation	2-13
Chapter 3	Options and Accessories Installation	3-1
3.1	Accessory Installation	3-1
3.1.1	Emergency Pushbutton or Footswitch Installation.....	3-4
3.1.2	Horn and Lights (External Alarm) Relay	3-5
3.1.3	External Speaker	3-6
Chapter 4	Best Practices: Installation & Troubleshooting.....	4-1
4.1	Check Wiring of Ignition and Radio Ignition Sensing.....	4-1
4.2	Check Physical Installation of Radio Ground and Radio Accessory Wiring.....	4-2
4.3	Improve the Electrical Quality of the Power and Ignition Lines.....	4-2
4.4	Jump-Start the Vehicle	4-3
Appendix A	Replacement Parts Ordering.....	A-1
A.1	Basic Ordering Information	A-1
A.2	Motorola Online	A-1
A.3	Mail Orders	A-1
A.5	Fax Orders.....	A-2
A.6	Parts Identification	A-2
A.7	Product Customer Service.....	A-2
Appendix B	Motorola Service Centers	B-1
B.1	Servicing Information	B-1
B.2	Motorola Service Center	B-1
B.3	Motorola Federal Technical Center	B-1
B.4	Motorola Canadian Technical Logistics Center	B-1
Index	Index-1

List of Figures

Figure 1-1	Front View of Dash Mount Trunnion for MOTOTRBO CM200d/CM300d and XPR 2500 Mobile Radios	1-1
Figure 1-2	Side View of Dash Mount with Low Profile Trunnion for MOTOTRBO CM200d/CM300d and XPR 2500 Mobile Radios.....	1-2
Figure 1-3	Back View of the Mobile Radio	1-3
Figure 1-4	Dash Mount Configuration	1-4
Figure 2-1	Typical Dash Mount Configuration.....	2-1
Figure 2-2	Radio Installation (Dash Mount).....	2-2
Figure 2-3	Trunnion Orientation for Above or Below Mobile	2-3
Figure 2-4	Transmission Hump Trunnion Mounting	2-4
Figure 2-5	Below Dash Trunnion Mounting.....	2-5
Figure 2-6	Locking Kit (Optional).....	2-6
Figure 2-7	Dashboard Mounting.....	2-7
Figure 2-8	Cabling Interconnect Diagram for Dash Mount.....	2-9
Figure 2-9	Antenna Connections on the Back of the Radio	2-11
Figure 2-10	Mini-UHF Connection	2-12
Figure 3-1	Location of the Rear Accessory Connector	3-1
Figure 3-2	Pin Configuration of Rear Accessory Connector for the CM200d/CM300d Series Mobile Radio (as viewed from the rear of the radio).....	3-2
Figure 3-3	Pin Configuration of Rear Accessory Connector for the XPR 2500 Mobile Radio (as viewed from the rear of the radio)	3-3
Figure 3-4	Emergency Switch Wiring Diagram using a CM200d/CM300d Series Mobile Radio (a XPR 2500 Mobile Radio is wired the same way)	3-4
Figure 3-5	Horn and Lights Wiring Diagram using a CM200d/CM300d Series Mobile Radio (a XPR 2500 Mobile Radio is wired the same way)	3-5
Figure 3-6	External Speaker Mounting.....	3-6

Related Publications

MOTOTRBO CM200d/300d Mobile Basic Service Manual	68009618001
MOTOTRBO XPR 2500 Mobile Basic Service Manual.....	68009620001

Mobile Radio Model Numbering Scheme

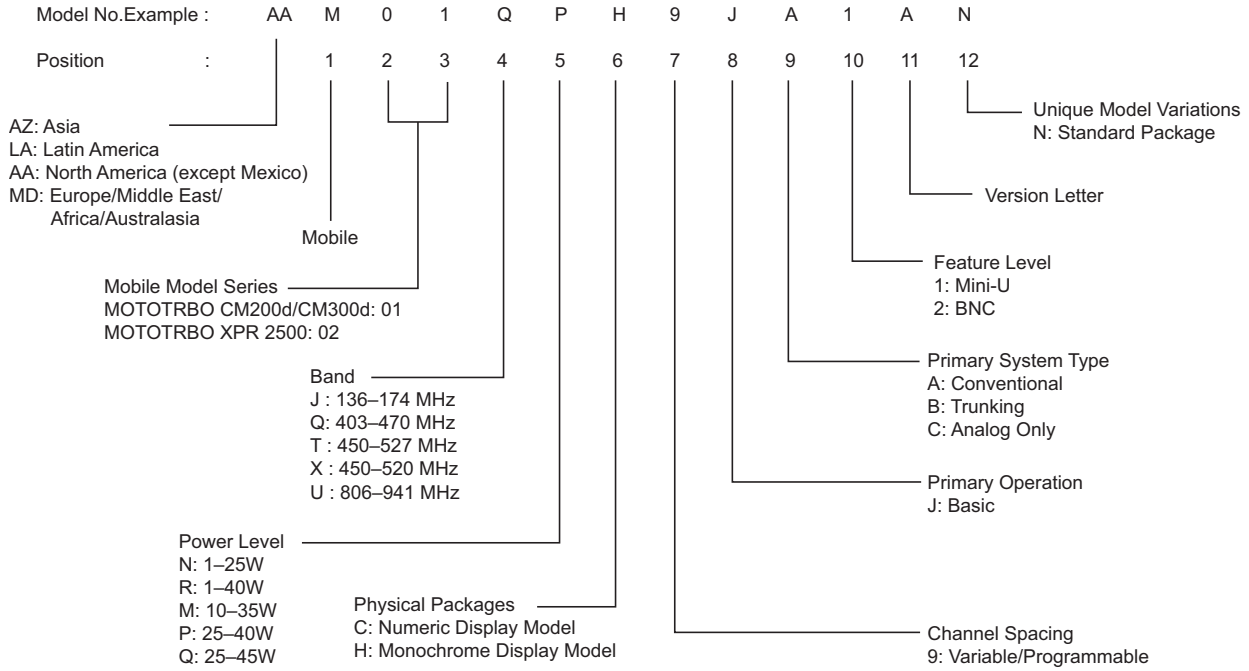

Commercial Warranty

Limited Warranty

MOTOROLA COMMUNICATION PRODUCTS

I. What This Warranty Covers and For How Long

MOTOROLA INC. ("MOTOROLA") warrants the MOTOROLA manufactured Communication Products listed below ("Product") against defects in material and workmanship under normal use and service for a period of time from the date of purchase as scheduled below:

CM200d/CM300d and XPR 2500 Mobile Radio	Two (2) Years
Product Accessories	One (1) Year

The mobiles additionally ship with a standard 1-year Repair Service Advantage (RSA) (for U.S. customers) or 1-year Extended Warranty (for Canada customers). However, at the time of order, you may choose to omit these warranties. For more RSA or Extended Warranty information, please refer to the price pages or Motorola Online (<http://www.motorola.com/businessonline>) > Resource Center > Services > Service Product Offerings > Repair Service Advantage or Extended Warranty.

Motorola, at its option, will at no charge either repair the Product (with new or reconditioned parts), replace it (with a new or reconditioned Product), or refund the purchase price of the Product during the warranty period provided it is returned in accordance with the terms of this warranty. Replaced parts or boards are warranted for the balance of the original applicable warranty period. All replaced parts of Product shall become the property of MOTOROLA.

This express limited warranty is extended by MOTOROLA to the original end user purchaser only and is not assignable or transferable to any other party. This is the complete warranty for the Product manufactured by MOTOROLA. MOTOROLA assumes no obligations or liability for additions or modifications to this warranty unless made in writing and signed by an officer of MOTOROLA. Unless made in a separate agreement between MOTOROLA and the original end user purchaser, MOTOROLA does not warrant the installation, maintenance or service of the Product.

MOTOROLA cannot be responsible in any way for any ancillary equipment not furnished by MOTOROLA which is attached to or used in connection with the Product, or for operation of the Product with any ancillary equipment, and all such equipment is expressly excluded from this warranty. Because each system which may use the Product is unique, MOTOROLA disclaims liability for range, coverage, or operation of the system as a whole under this warranty.

II. General Provisions

This warranty sets forth the full extent of MOTOROLA'S responsibilities regarding the Product. Repair, replacement or refund of the purchase price, at MOTOROLA's option, is the exclusive remedy. THIS WARRANTY IS GIVEN IN LIEU OF ALL OTHER EXPRESS WARRANTIES. IMPLIED WARRANTIES, INCLUDING WITHOUT LIMITATION, IMPLIED WARRANTIES OF MERCHANTABILITY AND FITNESS FOR A PARTICULAR PURPOSE, ARE LIMITED TO THE DURATION OF THIS LIMITED WARRANTY. IN NO EVENT SHALL MOTOROLA BE LIABLE FOR DAMAGES IN EXCESS OF THE PURCHASE PRICE OF THE PRODUCT, FOR ANY LOSS OF USE, LOSS OF TIME, INCONVENIENCE, COMMERCIAL LOSS, LOST PROFITS OR SAVINGS OR OTHER INCIDENTAL, SPECIAL OR CONSEQUENTIAL DAMAGES ARISING OUT OF THE USE OR INABILITY TO USE SUCH PRODUCT, TO THE FULL EXTENT SUCH MAY BE DISCLAIMED BY LAW.

III. State Law Rights

SOME STATES DO NOT ALLOW THE EXCLUSION OR LIMITATION OF INCIDENTAL OR CONSEQUENTIAL DAMAGES OR LIMITATION ON HOW LONG AN IMPLIED WARRANTY LASTS, SO THE ABOVE LIMITATION OR EXCLUSIONS MAY NOT APPLY.

This warranty gives specific legal rights, and there may be other rights which may vary from state to state.

IV. How to Get Warranty Service

You must provide proof of purchase (bearing the date of purchase and Product item serial number) in order to receive warranty service and, also, deliver or send the Product item, transportation and insurance prepaid, to an authorized warranty service location. Warranty service will be provided by Motorola through one of its authorized warranty service locations. If you first contact the company which sold you the Product, it can facilitate your obtaining warranty service. You can also call Motorola at 1-888-567-7347 US/Canada.

V. What This Warranty Does Not Cover

- A. Defects or damage resulting from use of the Product in other than its normal and customary manner.
 - B. Defects or damage from misuse, accident, water, or neglect.
 - C. Defects or damage from improper testing, operation, maintenance, installation, alteration, modification, or adjustment.
 - D. Breakage or damage to antennas unless caused directly by defects in material workmanship.
 - E. A Product subjected to unauthorized Product modifications, disassemblies or repairs (including, without limitation, the addition to the Product of non-Motorola supplied equipment) which adversely affect performance of the Product or interfere with Motorola's normal warranty inspection and testing of the Product to verify any warranty claim.
 - F. Product which has had the serial number removed or made illegible.
 - G. Rechargeable batteries if:
 - any of the seals on the battery enclosure of cells are broken or show evidence of tampering.
 - the damage or defect is caused by charging or using the battery in equipment or service other than the Product for which it is specified.
 - H. Freight costs to the repair depot.
-

-
- I. A Product which, due to illegal or unauthorized alteration of the software/firmware in the Product, does not function in accordance with MOTOROLA's published specifications or the FCC type acceptance labeling in effect for the Product at the time the Product was initially distributed from MOTOROLA.
 - J. Scratches or other cosmetic damage to Product surfaces that does not affect the operation of the Product.
 - K. Normal and customary wear and tear.

VI. Patent and Software Provisions

MOTOROLA will defend, at its own expense, any suit brought against the end user purchaser to the extent that it is based on a claim that the Product or parts infringe a United States patent, and MOTOROLA will pay those costs and damages finally awarded against the end user purchaser in any such suit which are attributable to any such claim, but such defense and payments are conditioned on the following:

- A. that MOTOROLA will be notified promptly in writing by such purchaser of any notice of such claim;
- B. that MOTOROLA will have sole control of the defense of such suit and all negotiations for its settlement or compromise; and
- C. should the Product or parts become, or in MOTOROLA's opinion be likely to become, the subject of a claim of infringement of a United States patent, that such purchaser will permit MOTOROLA, at its option and expense, either to procure for such purchaser the right to continue using the Product or parts or to replace or modify the same so that it becomes noninfringing or to grant such purchaser a credit for the Product or parts as depreciated and accept its return. The depreciation will be an equal amount per year over the lifetime of the Product or parts as established by MOTOROLA.

MOTOROLA will have no liability with respect to any claim of patent infringement which is based upon the combination of the Product or parts furnished hereunder with software, apparatus or devices not furnished by MOTOROLA, nor will MOTOROLA have any liability for the use of ancillary equipment or software not furnished by MOTOROLA which is attached to or used in connection with the Product. The foregoing states the entire liability of MOTOROLA with respect to infringement of patents by the Product or any parts thereof.

Laws in the United States and other countries preserve for MOTOROLA certain exclusive rights for copyrighted MOTOROLA software such as the exclusive rights to reproduce in copies and distribute copies of such Motorola software. MOTOROLA software may be used in only the Product in which the software was originally embodied and such software in such Product may not be replaced, copied, distributed, modified in any way, or used to produce any derivative thereof. No other use including, without limitation, alteration, modification, reproduction, distribution, or reverse engineering of such MOTOROLA software or exercise of rights in such MOTOROLA software is permitted. No license is granted by implication, estoppel or otherwise under MOTOROLA patent rights or copyrights.

VII. Governing Law

This Warranty is governed by the laws of the State of Illinois, USA.

Notes

Chapter 1 Introduction

This manual covers the installation procedures for CM200d/CM300d and XPR 2500 Mobile Radio and accessories required to complete the radio system. The radio system consists of a control head, radio, antenna, microphone, speaker, cabling, and accessories.

1.1 Mobile Radio Description

1.1.1 Overview

Model	Description
CM200d	Numeric Display model with 2 programmable buttons and a 2-character 7-segment display.
CM300d	Alphanumeric Display model with 4 programmable buttons and a dot-matrix LCD.
XPR 2500	Alphanumeric Display model with 4 programmable buttons, dot-matrix LCD, and premium system software features available.

1.1.2 Dimensions

Figure 1-1, Figure 1-2, Figure 1-3 and Figure 1-4 show the basic dimensions of the dash mount trunion of the mobile radio.

When installing the radio, make sure to plan the installation carefully and leave additional room in the rear of the radio for cabling and accessory connections; in the front of the radio for access, controls, and cabling; and to the sides of the radio so that you may access and install the trunion wing screws.

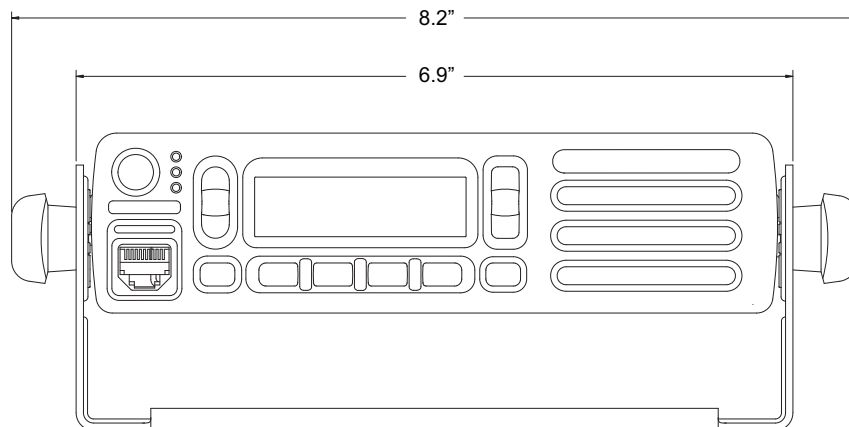

Figure 1-1 Front View of Dash Mount Trunion for MOTOTRBO CM200d/CM300d and XPR 2500 Mobile Radios

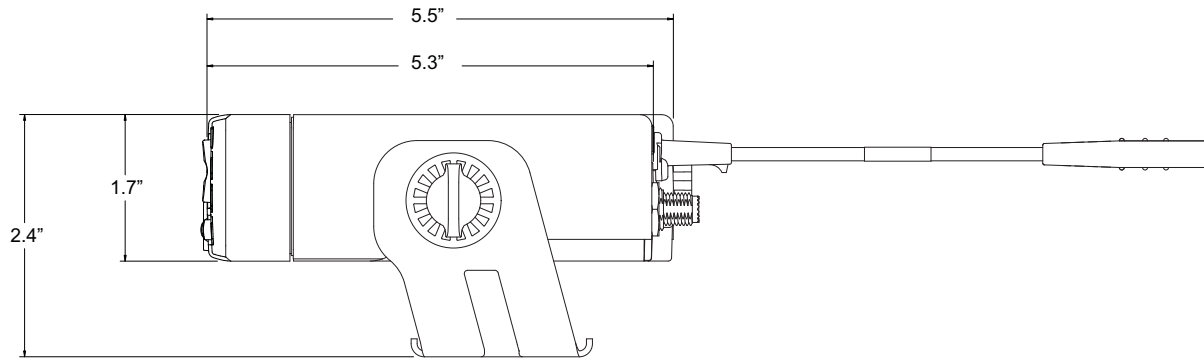

Figure 1-2 Side View of Dash Mount with Low Profile Trunnion for MOTOTRBO CM200d/CM300d and XPR 2500 Mobile Radios

NOTE: The MOTOTRBO CM200d/CM300d and XPR 2500 Mobile Radios use wing screws with thread length of 0.39 in. (9.9 mm) to secure the radio to the mounting trunnion.

NOTE: If the CM200/CM300 or PM400 Series Mobile Trunnion kits are reused, the wing screws need to be replaced with WING, M5 X 9.9 (03012045001).

1.1.3 Connections on the Back of the Radio

Figure 1-3 shows the connections that are found on the back of the radio.

For complete pin configuration of the rear accessory connector, see [Figure 3-2 on page 3-2](#).

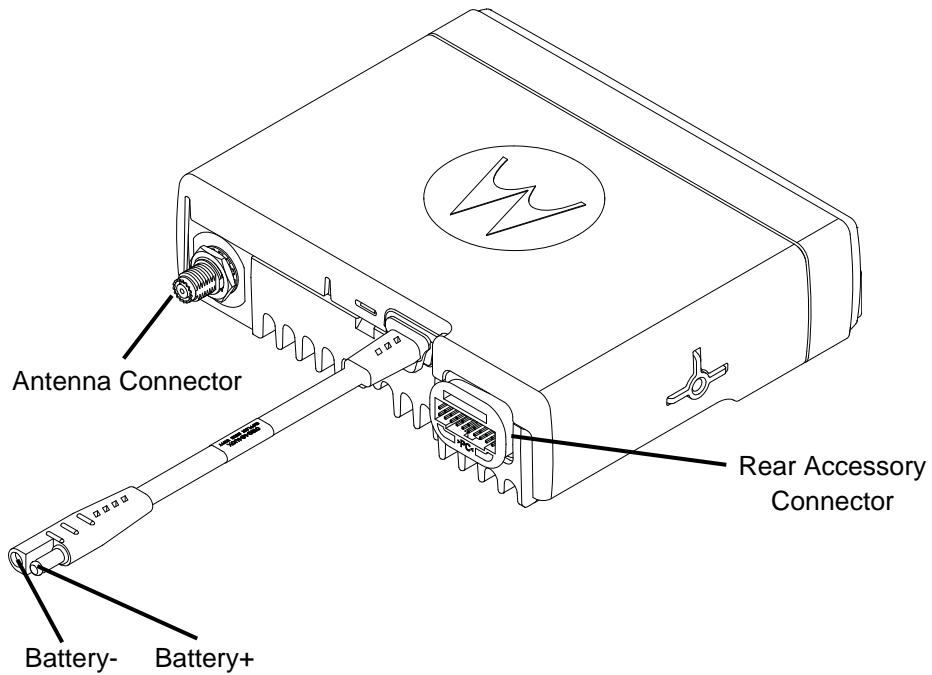

Figure 1-3 Back View of the Mobile Radio

1.2 Standard Configurations

The CM200d/CM300d and XPR 2500 Mobile Radios can only be dash mounted.

1.2.1 Dash Mount Configuration

In the dash mount configuration of the mobile radio, the control head is mounted on the front of the transceiver housing. Electrical connection between the two takes place within the radio via a flexible cable between the connectors on the front of the transceiver and at the back of the control head.

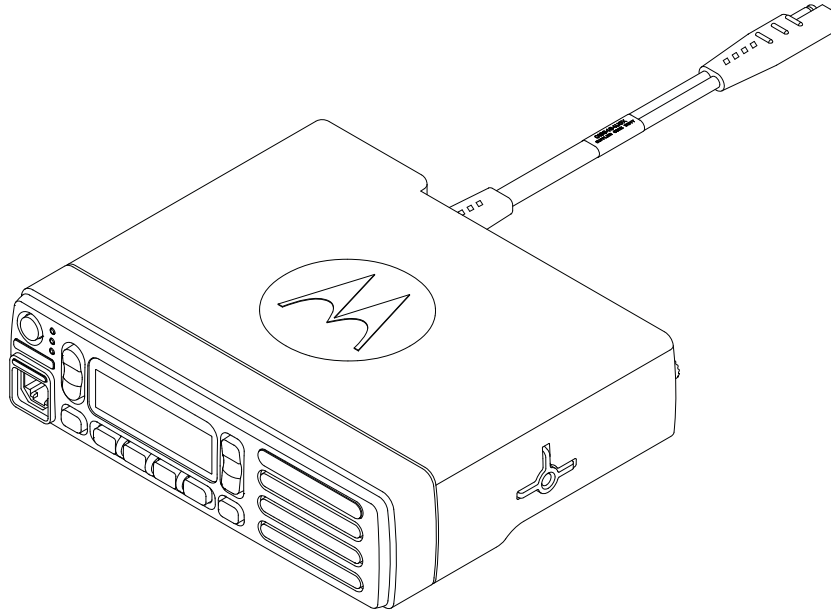

Figure 1-4 Dash Mount Configuration

For details on this configuration, see [Section 2.2.1 on page 2-4](#).

Chapter 2 Installation Details for Standard Configurations

2.1 Planning the Installation

The mobile radio operates only in negative ground electrical systems. Before starting the radio installation, make sure that the ground polarity of the vehicle is correct. Accidentally reversing the polarity will not damage the radio, but will cause the cable fuses to blow.

Planning is the key to fast, easy radio installation. Before starting the installation, inspect the vehicle and determine how and where you intend to mount the antenna, radio, and accessories. Plan wire and cable runs to provide maximum protection from pinching, crushing, and overheating.



Before installing any electrical equipment, check the vehicle manufacturer's user manual. The installation of this device should be completed by an authorized servicer or installer.

2.1.1 Tools Required for Installation

Tool	Motorola Part Number
Rubber-coated pliers	—
Regular slot screwdriver or Phillips #2	—
Pin removal tool	6680163F01
1/4 hex driver	—
11/32 hex driver	—

2.1.2 Installation Example

The mobile two-way radio offers various methods of installation, with accessories placed to the vehicle as desired. The radio can only be installed in a dash mount configuration. See [Figure 2-1](#).

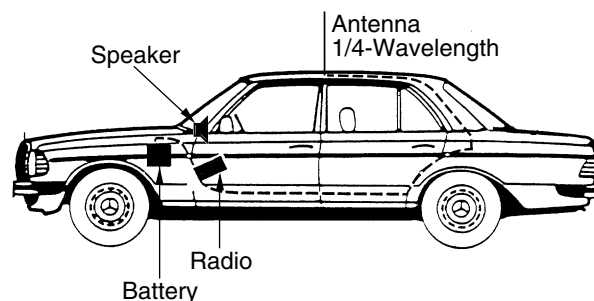

Figure 2-1 Typical Dash Mount Configuration

2.1.3 Wiring Diagrams

Figure 2-2 shows the wiring diagrams for some of the possible configurations. Identify the configuration that you are installing, and use the diagram when planning the installation.

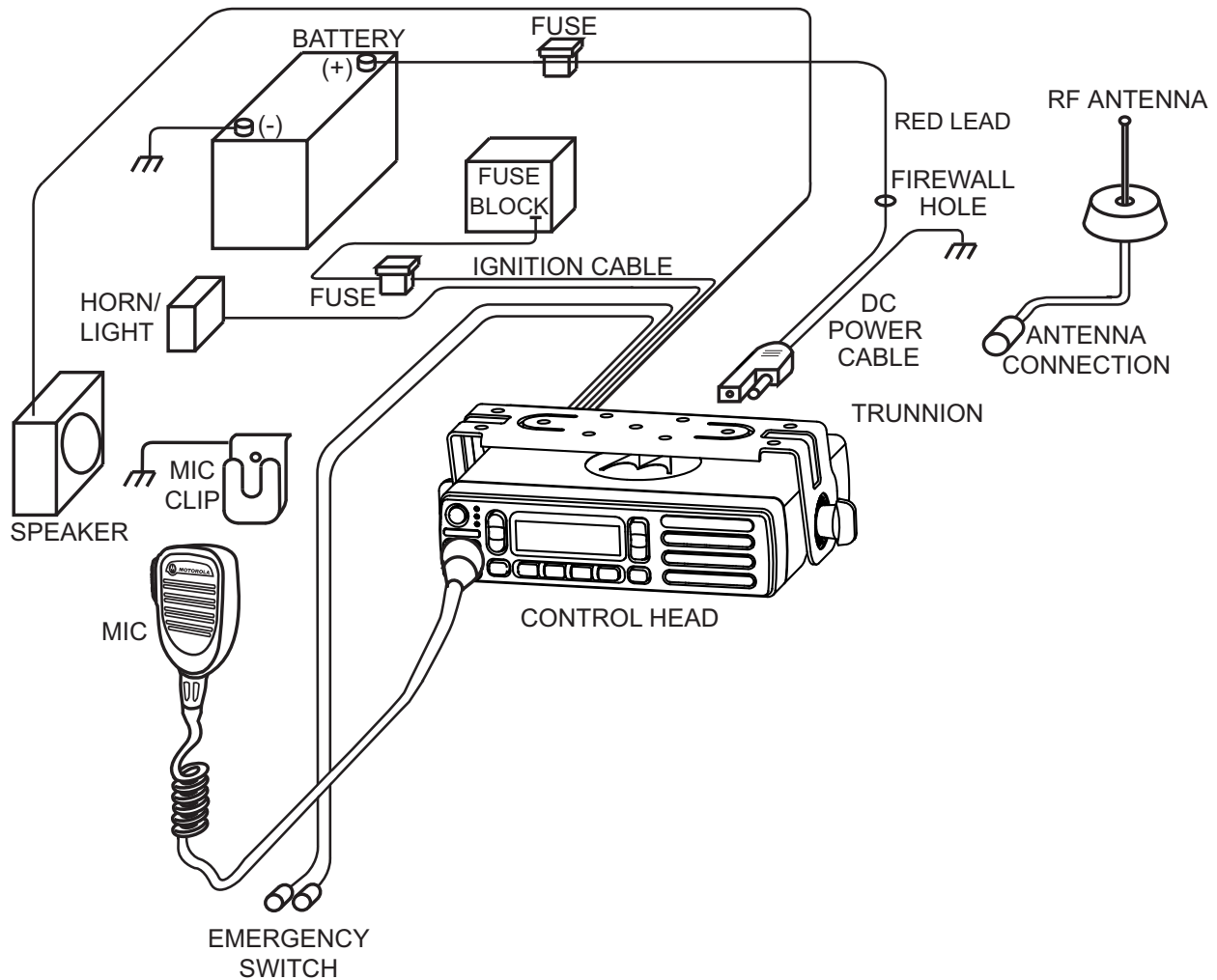

Figure 2-2 Radio Installation (Dash Mount)

(For complete rear accessory connector pin configuration, see [Figure 3-2](#), on page 3-2 for the CM200d/CM300d Series Mobile Radios and [Figure 3-3](#), on page 3-3 for the XPR 2500 Mobile Radio.)

2.2 Radio Mounting



DO NOT mount the radio on a plastic dashboard without first reinforcing the dashboard; the weight of the radio may crack or break the dashboard.



DO NOT mount the radio on a flat or concave surface where the radio could be partially submerged in water. This is especially important if the cab area of the vehicle is cleaned by spraying with water. If the radio sits in water for a length of time, moisture may seep inside the radio and damage the electronic components.



DO NOT allow water to stand in recessed areas of vertically mounted radios. Remove any moisture immediately to prevent it from seeping down into the radio.

The mounting location must be accessible and visible. Select a location that will permit routing the RF antenna cable as directly as possible.

For new or existing installations, use one of the mounting kits as specified in [Table 2-1](#). Orient the mounting trunnion as shown in [Figure 2-3](#).

Table 2-1. Mounting Kits

Mounting Kit	Motorola Part Number
Low Profile Trunnion Kit	RLN6466_
Low Profile Trunnion - Bag	RLN6469_
Standard Profile Trunnion Kit	RLN6467_
Key Lock Trunnion Kit	RLN6468_
DIN Mount	FTN6083_

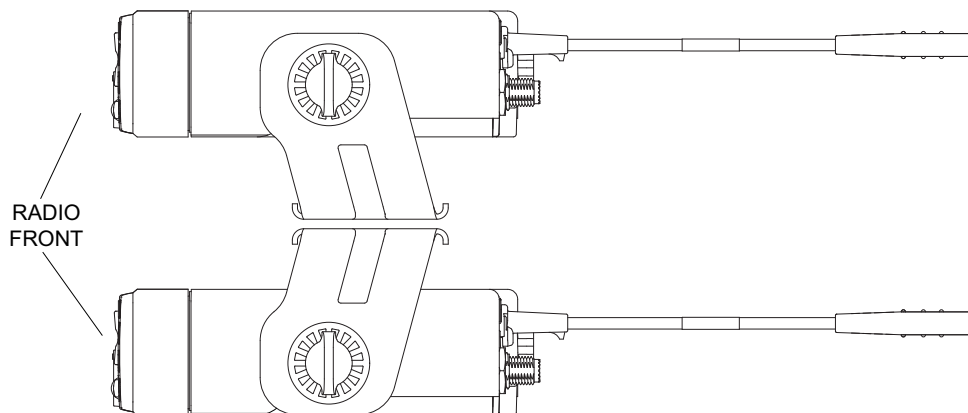

Figure 2-3 Trunnion Orientation for Above or Below Mobile

2.2.1 Dash Mount with Trunnion

1. Select the location to mount your radio on the transmission hump (see [Figure 2-4](#)) or under the dash (see [Figure 2-5](#)). When mounting the trunnion on the transmission hump take care the transmission housing is not affected.
2. Using the trunnion mounting bracket as a template, mark the positions of the holes on the mounting surface. Use the innermost four holes for a curved mounting surface such as the transmission hump, and the four outermost holes for a flat surface such as under the dash.
3. Center punch the spots you have marked and realign the trunnion in position.
4. Secure the trunnion mounting bracket with the self-drilling screws provided. The number of screws used will depend on how the radio is mounted (see [Figure 2-4](#) and [Figure 2-5](#)).
5. Position the radio to align the trunnion with the trunnion mounting features on the radio (see [Figure 2-4](#)). Secure the radio with the two wing screws and lock washers (position the flat side of the washer to the thumbscrew and the washer sharp side to the trunnion) provided.

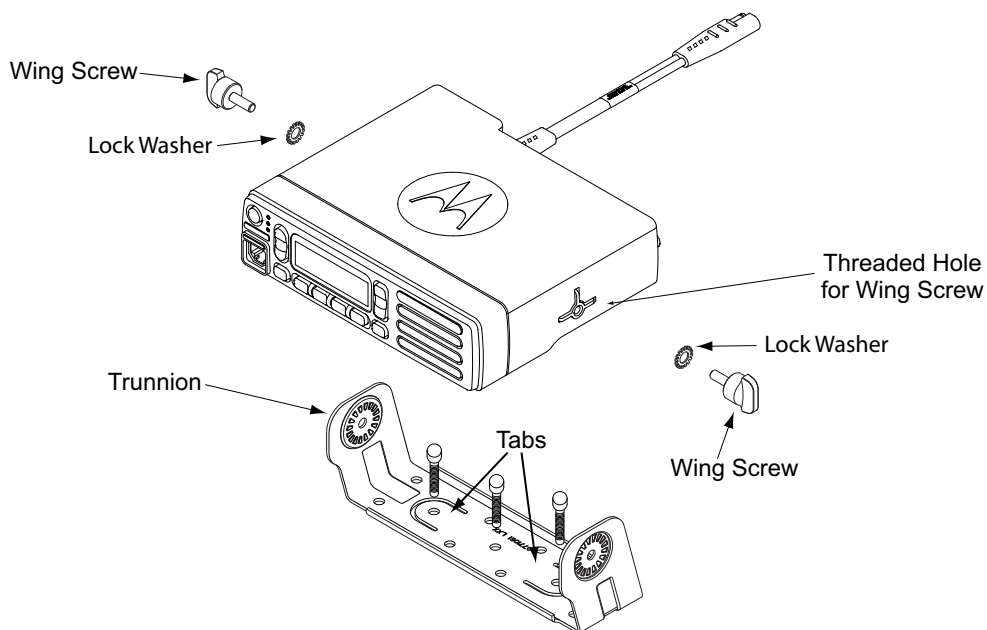

Figure 2-4 Transmission Hump Trunnion Mounting

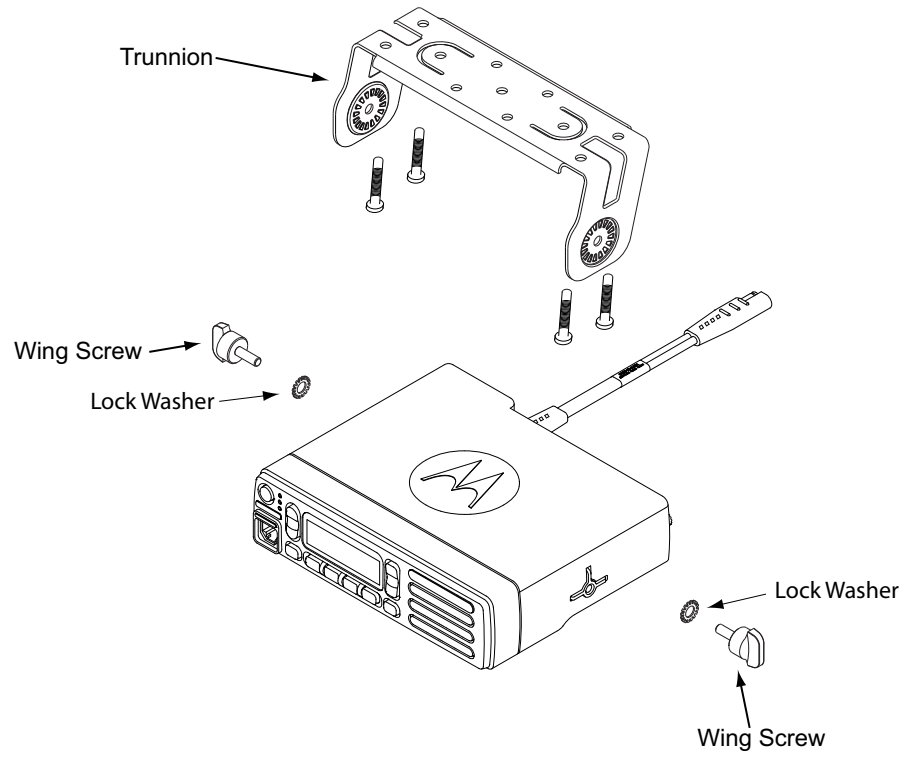

Figure 2-5 Below Dash Trunnion Mounting

2.2.2 Locking Kit (Optional)

2.2.2.1 All Radios

If an optional locking kit is used (shown in [Figure 2-6](#)), position the lock bottom housing on the trunnion before installing the radio mounting screws. Then slip the top lock housing on and remove the key. You can install the lock on either side of the radio.

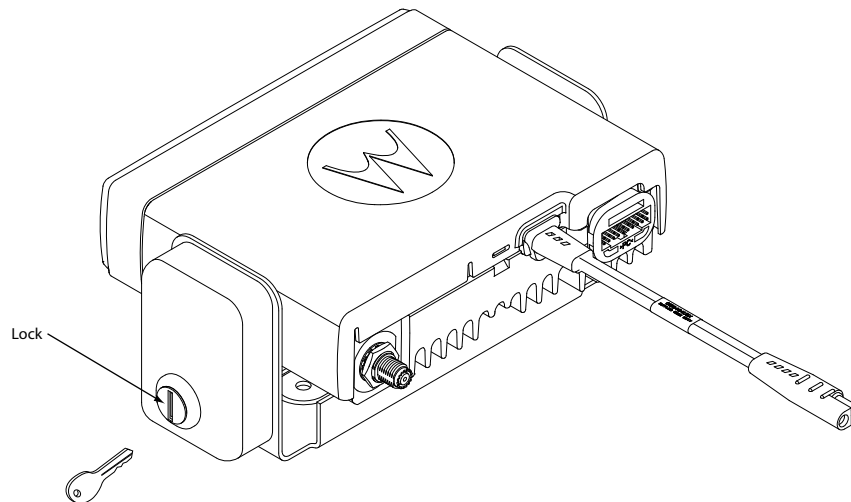

Figure 2-6 Locking Kit (Optional)

2.2.3 DIN Mount

2.2.3.1 To install the frame into the dashboard

1. Open up the radio cut-out in the dashboard to ISO7736 specification (182 mm x 53 mm).
2. Insert the mounting frame into the cut-out and retain it by bending back the relevant fixing tabs (using all 6 where possible). Check the orientation of the frame is correct by ensuring that the word "TOP" is uppermost.

NOTE: The tabs are easily bent back by twisting a large flat-head screwdriver in the slot behind the tabs.

NOTE: For a more secure installation the frame should also be secured with the appropriate number of screws to the mounting conditions (min. 1).

NOTE: The demounting tool can be used as an aid to mounting as well as demounting.

2.2.3.2 To Mount the radio in the frame

1. Provide the electrical connections for the radio (power, antenna, accessories).
2. Plug in all the connectors and push the radio firmly into the mounting frame until the two springs snap into place (shown in [Figure 2-7](#)).

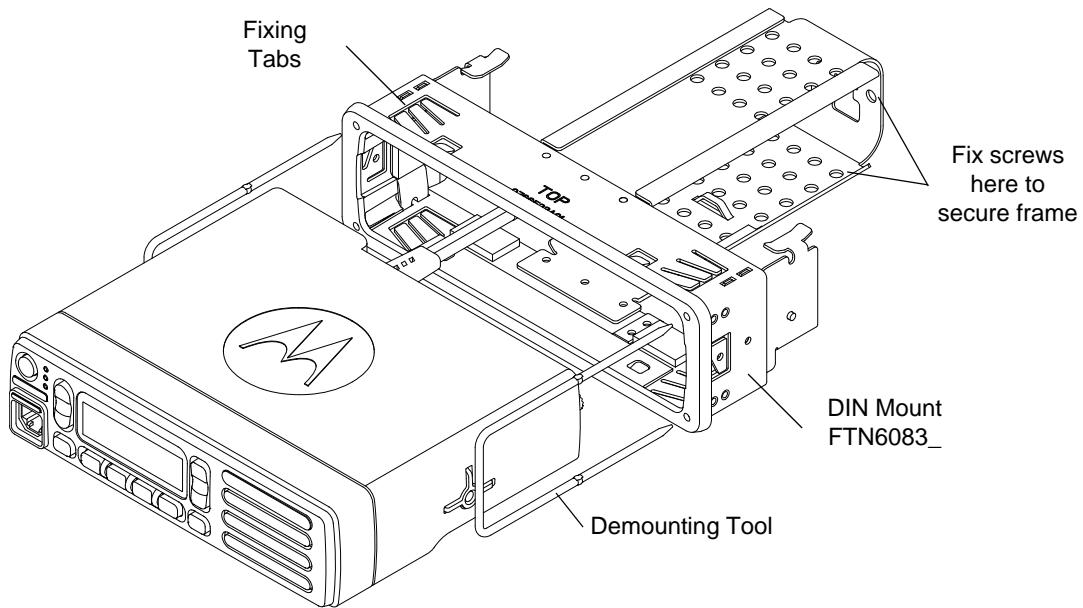

Figure 2-7 Dashboard Mounting

2.2.3.3 To Remove the radio from the frame

1. Push the two demounting tools through the openings in the frame until the two springs release the radio.
2. Slide out the radio.

NOTE: The fixing tabs should be checked for tightness each time the radio is removed. The tabs are easily tightened by twisting a large flat-head screwdriver in the slot behind the tabs.

NOTE: The frame is not designed for regular mounting and demounting.

2.3 Power Cable

Route the red radio power cable from the radio to the vehicle's battery compartment, using accepted industry methods and standards. Be sure to grommet the firewall hole to protect the cable. Remove the 15-Amp (part number 6580283E06) or 20-Amp (part number 6580283E07) fuse from the fuseholder and connect the red lead of the radio power cable to the positive battery terminal using the hardware provided as shown in [Figure 2-8](#). Connect the black lead to a convenient solid chassis ground point. DO NOT connect the black lead directly to the battery's negative terminal.

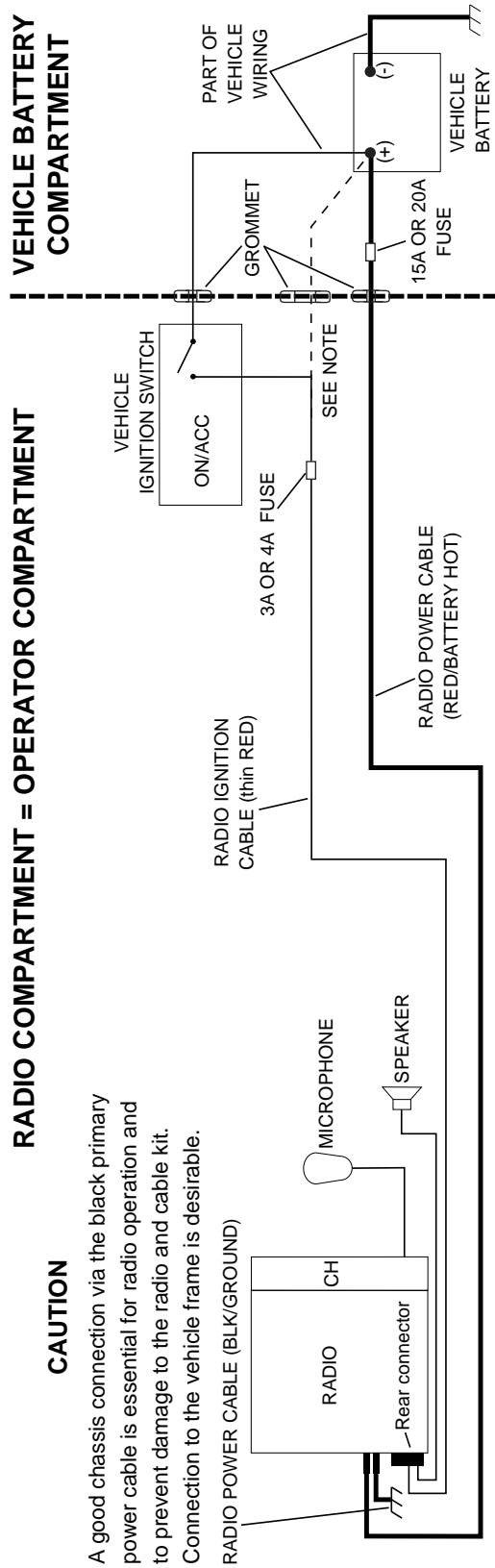

NOTE:
Caution: if you choose to connect the radio's IGNITION line directly to the car's battery, excess use of the radio when the car's ignition is not running (i.e. alternator running) could result in a slow discharge of the car's battery. This configuration allows the radio to operate with the car's ignition switch ON or OFF.
If the radio's IGNITION line is wired to the car's ignition switch, the radio will only function when the car's ignition switch is turned ON.

Figure 2-8 Cabling Interconnect Diagram for Dash Mount

2.4 Ignition Sense Cable

Motorola supplies an ignition sense cable (HKN9327_R) and recommends that it be used with every *mobile* installation. The ignition sense cable allows the radio to be turned on and off with the vehicle ignition switch, and allows the radio to “remember” the state of the radio on/off switch, even if it is changed while the vehicle is off.

- For radio ON/OFF control independent of the ignition switch, connect the red ignition cable (pin 10 of accessory connector) to “battery hot” at the vehicle fuse block.
- For radio ON/OFF control via the ignition switch, connect the red ignition cable to “ignition” at the fuse block.

The ignition sense cable uses either a 3-Amp (P/N 6500139764) or 4-Amp (P/N 6580283E02) fuse.

For other considerations when connecting the ignition cable, see the MOTOTRBO CM200d/300d Basic Service Manual (Motorola publication part number 68009618001) or XPR 2500 Basic Service Manual (Motorola publication part number 68009620001).

2.5 Antenna Installation

IMPORTANT NOTE: To assure optimum performance and compliance with RF Energy Safety standards, these antenna installation guidelines and instructions are limited to metal-body vehicles with appropriate ground planes and take into account the potential exposure of back seat passengers and bystanders outside the vehicle.

NOTE: For mobile radios with rated power of 7 watts or less, the only installation restrictions are to use only Motorola approved antennas and install the antenna externally on metal body vehicles. For mobile radios with rated power greater than 7 Watts, always adhere to all the guidelines and restrictions in [Section 2.5.1](#) below.

2.5.1 Selecting an Antenna Site/Location on a Metal Body Vehicle

1. **External Installation** - Check the requirements of the antenna supplier and install the vehicle antenna external to a metal body vehicle in accordance with those requirements.
2. **Roof Top** - For optimum performance and compliance with RF Energy Safety Standards, mount the antenna in the center of the roof.
3. **Trunk Lid** - On some vehicles with clearly defined, flat trunk lids, the antennas of some radio models (see restrictions below) can also be mounted on the center area of the trunk lid. For vehicles without clearly defined, flat trunk lids (such as hatchback autos, sport utility vehicles, and pick-up trucks), mount the antenna in the center of the roof.

BEFORE INSTALLING AN ANTENNA ON THE TRUNK LID,

- Be sure that the distance from the antenna location on the trunk lid will be at least 85 cm (33 in.) from the front surface of the rear seat-back to assure compliance with RF Energy Safety standards.

- Ensure that the trunk lid is grounded by connecting grounding straps between the trunk lid and the vehicle chassis.



Caution

If these conditions cannot be satisfied, then mount the antenna on the roof top.

4. Mounting restrictions for certain radio models

For all VHF and UHF models with the output power set to 30 watts or higher, the $\frac{1}{4}$ wave antenna shall be mounted *only in the center area of the roof*, not on the trunk lid, to assure compliance with *RF Energy Safety standards*.

5. Ensure the antenna cable can be easily routed to the radio. Route the antenna cable as far away as possible from the vehicle electronic control units and associated wiring.
6. Check the antenna location for any electrical interference.
7. Make sure the mobile radio antenna is installed at least 30 centimeters (1 foot) away from any other antenna on the vehicle.

NOTE: Any two metal pieces rubbing against each other (such as seat springs, shift levers, trunk and hood lids, exhaust pipes, etc.) in close proximity to the antenna can cause severe receiver interference.

2.5.2 Antenna Installation Procedure

1. Mount the antenna according to the instructions provided with the antenna kit. Run the coaxial cable to the radio mounting location. If necessary, cut off the excess cable and install the cable connector.
2. Connect the antenna cable connector to the radio antenna connector on the rear of the radio.

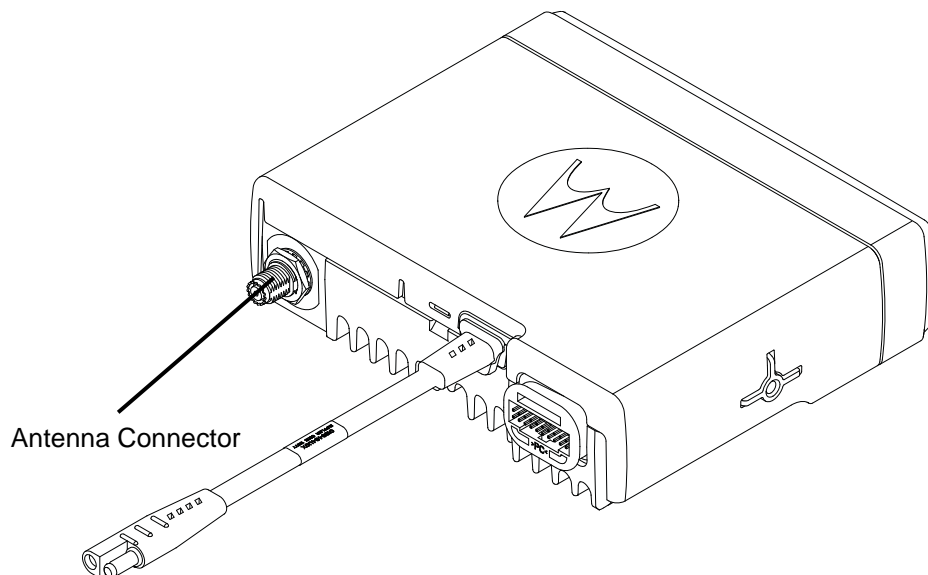

Figure 2-9 Antenna Connections on the Back of the Radio

2.5.3 Antenna Connection

To ensure a secure connection of an antenna cable's plug to a radio's jack, their interlocking features must be properly engaged. If they are not properly engaged, the system will loosen.

NOTE: Applying excessive force with a tool can cause damage to the antenna or the connector (e.g., stripping threads, deforming the collar or connector, or causing the connector to twist in the housing opening and break).

Motorola recommends the following sequence to ensure proper attachment of the system (see [Figure 2-10](#)):

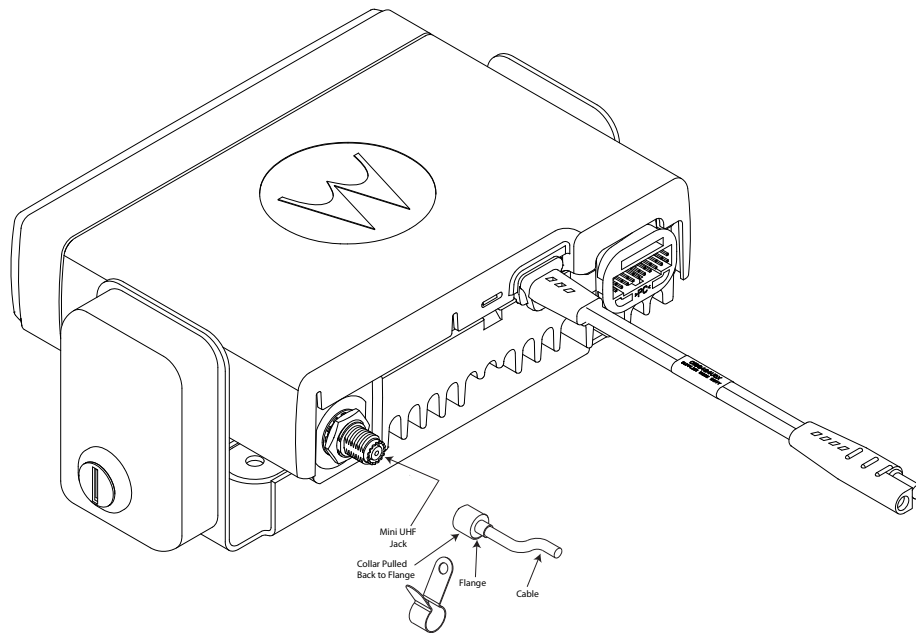

Figure 2-10 Mini-UHF Connection

1. Make sure that there is sufficient slack in the antenna cable.
2. Make sure that the collar of the antenna cable plug is loose and does not bind. Slide the collar back against the flange. Insert the antenna cable plug's pin fully into the radio jack, but do not engage the threads.
3. Ensure that the plug's and jack's interlocking features are fully seated. Check this by grasping the crimp on the cable jack, rotating the cable, and noting any movement. If the features are seated correctly, there should be NO movement.
4. Finger-tighten the antenna cable plug's collar onto the radio's jack.
5. Give a final tug, by hand, to the collar, and retighten by hand as firmly as possible.
6. Use the rubber-coated pliers to grip the plug's knurled collar, then turn clockwise to tighten the collar. It should take 1/4 turn or less. Turning counterclockwise loosens the collar.

NOTE: Overtightening the collar can damage the connector and the radio.

2.6 Microphone Hang-Up Clip

2.6.1 Standard Hang-Up Clip

The hang-up clip must be within reach of the operator(s). Measure this distance before actually mounting the bracket. Since the bracket has a positive-detent action, the microphone can be mounted in any position. The microphone hang-up clip must be grounded.

Use the hang-up clip as a template to locate the mounting holes. To avoid interference when removing the microphone, install the flathead screw in the top clip hole.

2.7 Completing the Installation

Complete the installation by connecting the power wires and plugging in the microphone cable to the mobile.

Chapter 3 Options and Accessories Installation

3.1 Accessory Installation

The accessories must be installed through the rear accessory connector that is located on the rear of the radio, adjacent to the power connector. Most of the Motorola-approved accessories are supplied with female terminals crimped to a 20-gauge wire specifically designed to fit the plug of the rear accessory connector.

Insert the female terminal into the accessory connector assembly in the appropriate locations. The accessory connector assembly is provided together with the accessory. Connect the accessory connector assembly to the rear accessory connector on the back of the mobile. Do not use other generic terminals in the plug. Generic terminals can cause electrical intermittences and may cause damage to the plug.

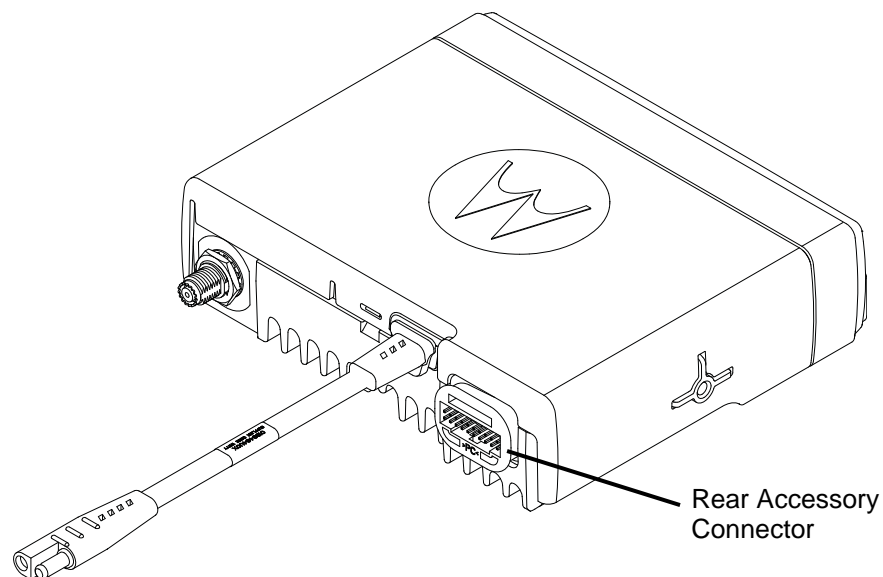

Figure 3-1 Location of the Rear Accessory Connector

Table 3-1 Rear Accessory Connector Pin Functions for the CM200d/CM300d Series Mobile Radio

Pin No.	Pin Name	Pin Function	Pin No.	Pin Name	Pin Function
1	Speaker-	Speaker – (3.2 ohm minimum impedance)	11	Rx Audio	Receive Live Audio ²
2	Ext Mic Audio	Rear External Microphone Input ⁴	12	GPIO_7	5V Level GPIO
3	GPI_1 (PTT)	5V Level GPI, PTT Input ¹	13	SWB+	Switched Battery Voltage
4	VIP_1 (Ext Alarm)	12V Supply, External Alarm	14	GPIO_8	5V Level GPIO
5	Flat Tx Audio	Data Input ³	15	RSSI	Receive Signal Strength Indicator ⁵
6	UART CTS	Motorola Internal Use Only ⁷	16	Speaker+	Speaker + (3.2 ohm minimum impedance)
7	Ground	Ground	17	UART TX	Motorola Internal Use Only ⁷
8	GPIO_4	5V Level GPIO	18	UART RX	Motorola Internal Use Only ⁷
9	Emergency SW	Emergency Switch Input	19	UART RTS	Motorola Internal Use Only ⁷
10	Ignition Sense	Ignition Sense Input ⁶	20	Ground	Ground

¹ Pulling this line to ground activates the Ext Mic Audio input

² Fixed level (independent of volume level) received audio signal, including alert tones. Flat or de-emphasis are programmed by CPS. Output voltage is approximately 330 mVrms per 1 kHz of deviation.

³ This input is for injecting signals into the transmit path that should not be filtered; for example, the analog output of a modem. The nominal input level is 150 mVrms for 60% deviation and the input impedance is greater than 25k.

⁴ This microphone signal is independent of the microphone signal on the front microphone connector. The nominal input level is 80 mVrms for 60% deviation. The DC impedance is 660 ohms and the AC impedance is 560 ohms.

⁵ A receive signal strength of -120 dBm gives about 1.12 Vdc at pin 15. A receive signal strength of -60 dBm gives about 2.44 Vdc at pin 15. The receive signal strength for levels in between can be linearly calculated. For signals strengths greater than -60 dBm, the voltage stays relatively flat at ~ 2.44 Vdc.

⁶ See [Figure 2-2](#) and [Figure 2-8](#) for wiring information.

⁷ **Caution:** Applying greater than 5 V to the pin can cause damage to the circuit.

**Figure 3-2** Pin Configuration of Rear Accessory Connector for the CM200d/CM300d Series Mobile Radio (as viewed from the rear of the radio)

Table 3-2 Rear Accessory Connector Pin Functions for the XPR 2500 Mobile Radio

Pin No.	Pin Name	Pin Function	Pin No.	Pin Name	Pin Function
1	Speaker-	Speaker – (3.2 ohm minimum impedance)	11	Rx Audio	Receive Live Audio ²
2	Ext Mic Audio	Rear External Microphone Input ⁴	12	GPIO_7	5V Level GPIO
3	GPI_1 (PTT)	5V Level GPI, PTT Input ¹	13	SWB+	Switched Battery Voltage
4	VIP_1 (Ext Alarm)	12V Supply, External Alarm	14	GPIO_8	5V Level GPIO
5	Flat Tx Audio	Data Input ³	15	RSSI	Receive Signal Strength Indicator ⁵
6	GPIO_3	5V Level GPIO	16	Speaker+	Speaker + (3.2 ohm minimum impedance)
7	Ground	Ground	17	USB D+	Universal Serial Bus Data + ⁷
8	GPIO_4	5V Level GPIO	18	USB D-	Universal Serial Bus Data - ⁷
9	Emergency SW	Emergency Switch Input	19	VBUS	USB Power (5V from USB Cable) ⁷
10	Ignition Sense	Ignition Sense Input ⁶	20	USB Ground	Universal Serial Bus Ground

- ¹ Pulling this line to ground activates the Ext Mic Audio input
- ² Fixed level (independent of volume level) received audio signal, including alert tones. Flat or de-emphasis are programmed by CPS. Output voltage is approximately 330 mVrms per 1 kHz of deviation.
- ³ This input is for injecting signals into the transmit path that should not be filtered; for example, the analog output of a modem. The nominal input level is 150 mVrms for 60% deviation and the input impedance is greater than 25k.
- ⁴ This microphone signal is independent of the microphone signal on the front microphone connector. The nominal input level is 80 mVrms for 60% deviation. The DC impedance is 660 ohms and the AC impedance is 560 ohms.
- ⁵ A receive signal strength of -120 dBm gives about 1.12 Vdc at pin 15. A receive signal strength of -60 dBm gives about 2.44 Vdc at pin 15. The receive signal strength for levels in between can be linearly calculated. For signals strengths greater than -60 dBm, the voltage stays relatively flat at ~ 2.44 Vdc.
- ⁶ See [Figure 2-2](#) and [Figure 2-8](#) for wiring information.
- ⁷ **Caution:** Applying greater than 5 V to the pin can cause damage to the circuit.

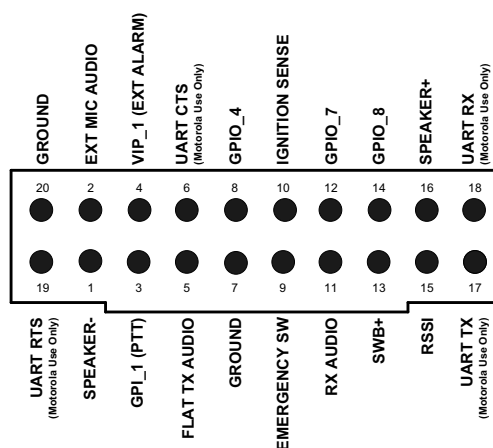
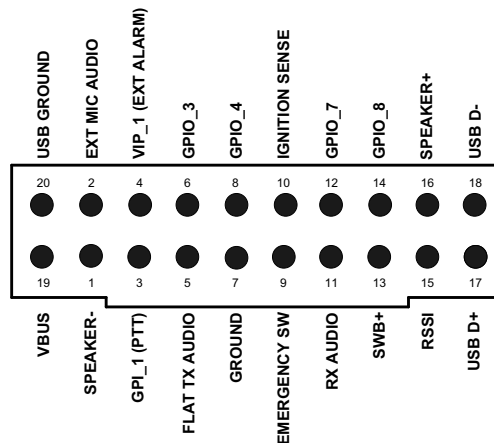

Figure 3-3 Pin Configuration of Rear Accessory Connector for the XPR 2500 Mobile Radio (as viewed from the rear of the radio)

3.1.1 Emergency Pushbutton or Footswitch Installation

Mount the emergency pushbutton (Motorola part number RLN4857_) or the footswitch (Motorola part number RLN4836AR_) using the hardware that comes with the kit. Press the terminal into the accessory connector housing. Connect the emergency switch wires to pins 9 and 7 (see [Figure 3-4](#)). Route the finished cable from the switch location to the control head location.

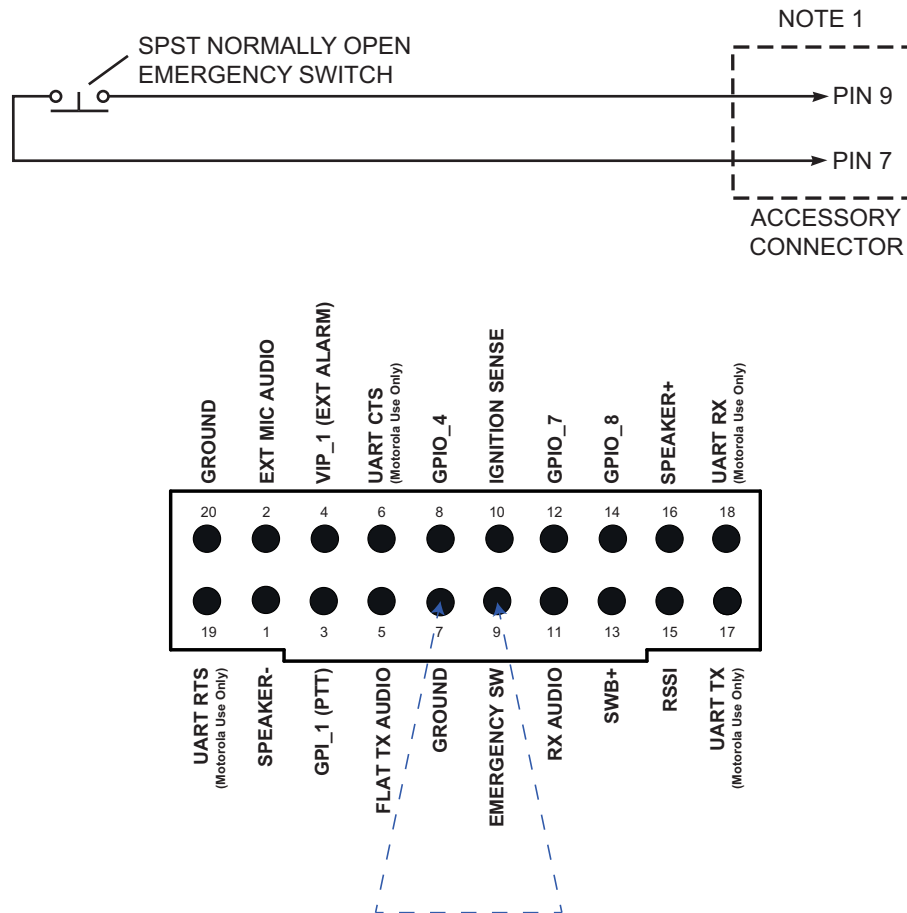

Figure 3-4 Emergency Switch Wiring Diagram using a CM200d/CM300d Series Mobile Radio (a XPR 2500 Mobile Radio is wired the same way)

3.1.2 Horn and Lights (External Alarm) Relay

Allows the user to be alerted to an incoming call when away from the vehicle. The vehicle's horn or lights or both are used depending on which option is connected to the accessory port. When the radio receives a call alert or emergency alarm/call, there is a delay before activating the horn and/or lights. The delay is programmable using the Horn & Lights Delay Time feature in the CPS. Once activated, the Horn and/or Lights remain active depending on the option selected. The Horn & Lights feature can be toggled between ON or OFF, via a short or long programmable button press (Horn & Lights On/Off) or Horn/Lights (Utilities Menu) feature.

For installations that use the horn/lights option, select a suitable location for mounting (normally under the dash) and, referring to [Figure 3-5](#), perform the following procedure:

1. Horn Relay – Connect the relay contacts across the horn ring switch, typically found in the steering column. Connect the two control wires (female pins) into locations 4 and 7 of the connector.
2. Lights Relay – Connect the relay across the headlamp ON/OFF switch, typically found in the steering column. Connect the two control wires (female pins) into locations 4 and 7 of the accessory connector.

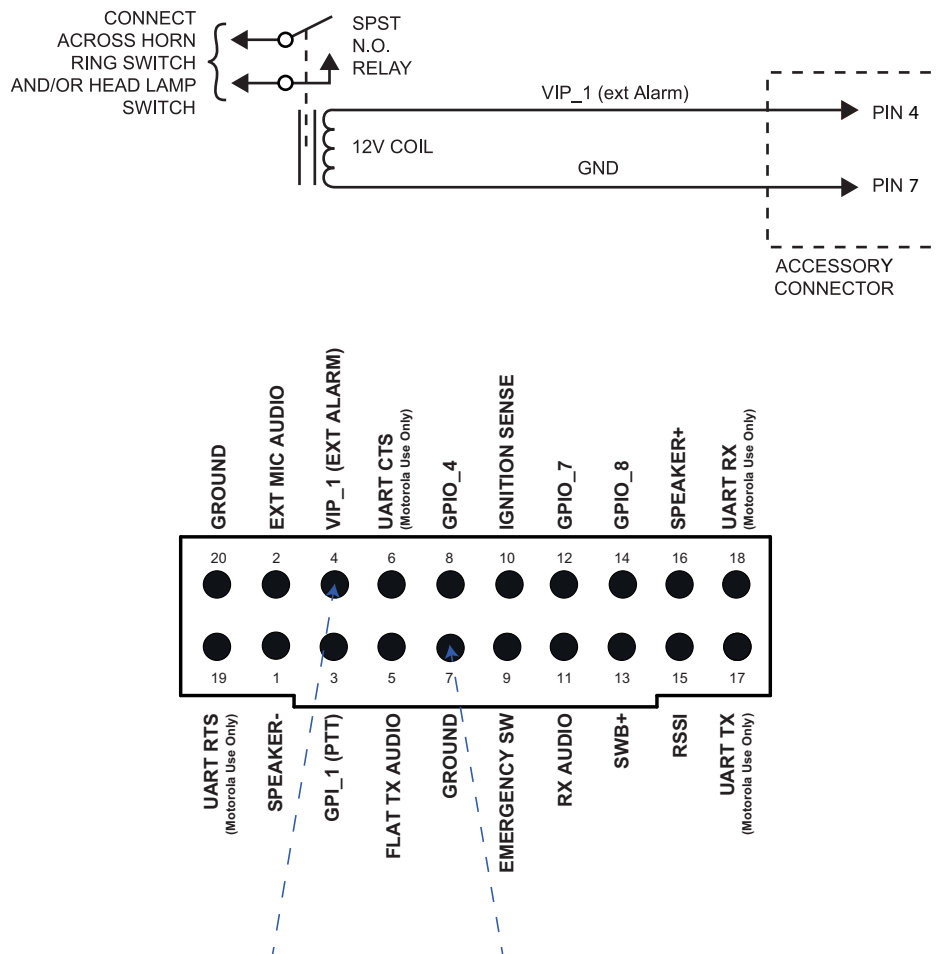

Figure 3-5 Horn and Lights Wiring Diagram using a CM200d/CM300d Series Mobile Radio (a XPR 2500 Mobile Radio is wired the same way)

3.1.3 External Speaker

**Caution**

DO NOT ground the radio's speaker leads. This system has a floating speaker output (dc voltage on both leads); damage to the audio circuit will result if either lead is grounded or if they are shorted together.

The external speaker kit includes a trunnion bracket that allows the speaker to be mounted in a variety of ways. With the trunnion bracket, the external speaker can mount permanently on the dashboard or in accessible firewall areas. The trunnion allows the external speaker to tilt for best operation. Mount the external speaker out of the way so that it will not be kicked or knocked around by the vehicle occupants. Mount the external speaker as follows:

1. Use the external speaker mounting bracket as a template to mark the mounting hole locations.
2. Use the self-drilling screws provided to fasten the trunnion.
3. Attach the external speaker and fasten to the trunnion with two wing screws.
4. Route the speaker wires under the carpet or floor covering, or behind the kick panels. Be sure the wires are out of the way and will not be snagged and broken by the occupants of the vehicle.

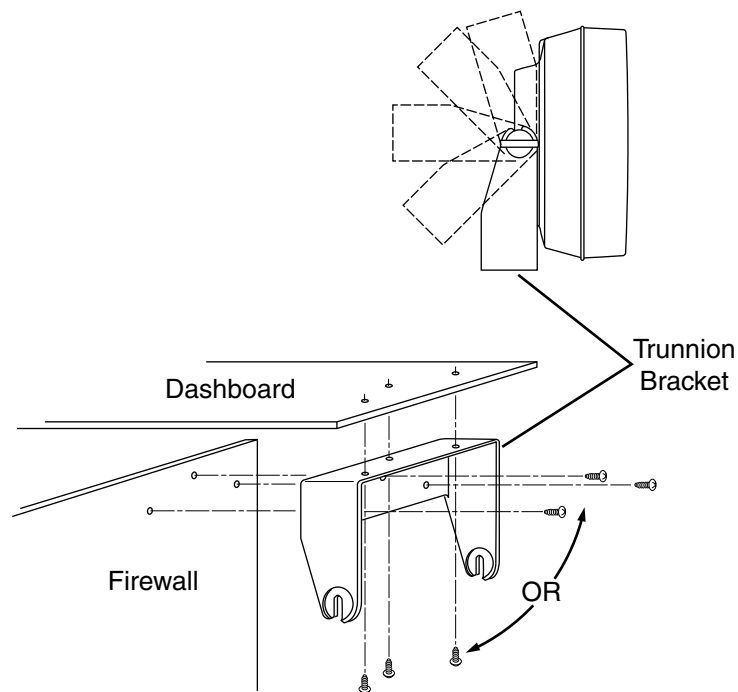

MAEPF-25764-O

Figure 3-6 External Speaker Mounting

Chapter 4 Best Practices: Installation & Troubleshooting

In this section are Motorola recommended vehicle installation practices that can address or prevent many issues, including:

- Radio circuit damage due to over voltage condition
- Radio/Accessories "lock up"
- Radio/Accessories change state/lock-up when radio PTT is depressed
- Radio intermittently resets
- Alternator whine present when transmitting with engine running
- Radio/Accessories turn themselves on/off

4.1 Check Wiring of Ignition and Radio Ignition Sensing

- If it is required to turn the radio on and off via the ignition sense switch, in addition to the control head's on/off switch, connect the ignition sense lead to the accessory terminal from the ignition switch (usually in the vehicle's fuse panel under accessory or radio).

NOTE: Motorola recommends protecting or isolating the radio's ignition sense input from voltage spikes in excess of +/- 40 VDC. Such spikes can be hundreds of volts in amplitude and are common in larger vehicles (utility trucks, buses and etc.), especially when the source is common to a solenoid coil. A triggerable oscilloscope is required to determine the existence of such spikes as most voltmeters cannot measure in short duration (< 1 msec). If the condition of the intended ignition sense source is unknown, Motorola recommends isolating the source from the radio with a relay or the use of a suppression diode wired between the source and ground. Any high current suppression diode (i.e. MR2535) with a breakdown voltage of between 18 and 40 volts will suffice. A suitable diode kit is available from Motorola parts, kit number HLN6325_.

- If it is required to have the radio power up only via the control head's on/off switch, then connect the ignition sense lead directly to the positive terminal of the battery. This will mean the ignition sense will always be ignored and a re-wiring will be necessary in the future if the operator chooses any ignition sense CPS setting.
-

4.2 Check Physical Installation of Radio Ground and Radio Accessory Wiring

- Take care to scrape away paint on the chassis at the place where the ground connection is to be made, and try to keep the ground lead as short as possible.
- Verify that the A+ lead (red) is connected directly to the positive terminal of the battery and the ground lead (black) is connected to the vehicle's chassis using as short of a length of wire as is practical.
- For vehicles that have other types of electronic equipment installed (lights, flashers, computers siren/PA and etc.), use a separate ground for the mobile radio equipment.
- Make sure that the mobile radio antenna is the minimum required distance (three feet) from the mobile radio equipment to prevent radio frequency interference (RFI) from interfering with the radio and/or accessories.
- Do not coil up any excess length of the A+ (red) lead. Doing this may cause a large transient voltage to be produced when there is a high current drain (e.g. during transmit). This could cause the radio to reset when the push-to-talk (PTT) is depressed.
- Do not coil up any excessive length of antenna cable, if possible. It may affect the radio's receive performance.

4.3 Improve the Electrical Quality of the Power and Ignition Lines

- Use a relay to isolate the vehicle's ignition switch point (ACC) from the radio's ignition sense point. Control this relay from the vehicle's ignition switch point (ACC). Supply a cleaner voltage from the positive terminal of the battery into the relay, which will now be attached to the radio's ignition sense point. Now the ACC line toggles the relay, instead of directly toggling the radios ignition sense line.
 - Install a Power Line Filter between the A+ lead and the positive terminal of the battery. This is intended to filter the battery power applied to the transmitter power amplifiers. Pay extra caution to this because the series filter will introduce a negative spike when the radio transmits that may cause problems with radio operation.
 - For vehicles that use electromechanical relays to control external devices (lights, motors, switch boxes and etc.), these relay circuits should be isolated as best as possible from the mobile radio equipment. Also, diode suppression should be used across the relay contacts to minimize the noise produced by the collapsing magnetic field.
 - If the ignition sense switch is to be used, make sure that there is not a large voltage drop between the A+ point (usually the positive terminal of the battery) and the ignition sense point. In general, the voltage difference between these two points, should not be greater than 1.5 volts when all accessories/air-conditioner, etc. are turned on. Refer to the Basic Service Manual for specifications for minimum and maximum voltage levels. Typical battery voltage levels are 13.6V +/- 20%.
-

4.4 Jump-Start the Vehicle



Caution

Do not jump-start vehicle with radio power or ignition sense cables connected. Damage to the radio and/or accessories may result.

The state of your radio prior to needing a jump-start may be unknown, and the radio may attempt to return to its last state (radio ON), when doing a jump-start. Therefore, Motorola recommends the following steps be taken before jump-starting any vehicle containing a radio.

1. Locate the ignition sense line and the main power leads (thick red wire) near the battery positive terminal.

NOTE: These lines are fused. In the event these lines are not fused (add the appropriate fuse in line) use whatever tools necessary to physically disconnect the ignition sense and power lines from the battery terminal.

2. Open up the fuse holders and remove the fuses out of the kits.
3. Re-tighten the fuse holders but without the fuses to insure that ignition sense and power lines do not interfere with any moving parts.
4. Proceed with the jump-start routine as described by your vehicle owner's manual.
5. Once the jump-start process is complete, re-install the fuses into their holders.

Appendix A Replacement Parts Ordering

A.1 Basic Ordering Information

When ordering replacement parts or equipment information, the complete identification number should be included. This applies to all components, kits, and chassis. If the component part number is not known, the order should include the number of the chassis or kit of which it is a part, and sufficient description of the desired component to identify it.

The MOTOTRBO CM200d/300d Mobile Basic Service Manual (Motorola publication part number 68009618001) or the XPR 2500 Mobile Basic Service Manual (Motorola publication part number 68009620001) includes the complete parts lists and part numbers.

A.2 Motorola Online

Motorola Online users can access our online catalog at:

<https://businessonline.motorolasolutions.com/>

To register for online access, please call 1-800-422-4210 (for U.S. and Canada Service Centers only). International customers can obtain assistance at:

<https://businessonline.motorolasolutions.com/>

A.3 Mail Orders

Mail orders are only accepted by the U.S. Federal Government Markets Division (USFGMD):

Motorola Inc.
7031 Columbia Gateway Drive
3rd Floor - Order Processing
Columbia, MD 21046
U.S.A.

A.4 Telephone Orders

Radio Products and Solutions Organization*
(United States and Canada)
7:00 AM to 7:00 PM (Central Standard Time)
Monday through Friday (Chicago, U.S.A.)
1-800-422-4210
1-847-538-8023 (United States and Canada)

U.S. Federal Government Markets Division (USFGMD)
1-877-873-4668
8:30 AM to 5:00 PM (Eastern Standard Time)

A.5 Fax Orders

Radio Products and Solutions Organization*
(United States and Canada)
1-800-622-6210
1-847-576-3023 (International)

USFGMD
(Federal Government Orders)
1-800-526-8641 (For Parts and Equipment Purchase Orders)

A.6 Parts Identification

Radio Products and Solutions Organization*
(United States and Canada)
1-800-422-4210

A.7 Product Customer Service

Radio Products and Solutions Organization (United States and Canada)
1-800-927-2744

* The Radio Products and Solutions Organization (RPSO) was formerly known as the Radio Products Services Division (RPSD) and/or the Accessories and Aftermarket Division (AAD).

Appendix B Motorola Service Centers

B.1 Servicing Information

If a unit requires further complete testing, knowledge and/or details of component level troubleshooting or service than is customarily performed at the basic level, please send the radio to a Motorola Service Center as listed below.

B.2 Motorola Service Center

1220 Don Haskins Drive
Suite A
El Paso, TX 79936
Tel: 915-872-8200

B.3 Motorola Federal Technical Center

10105 Senate Drive
Lanham, MD 20706
Tel: 1-800-969-6680
Fax: 1-800-784-4133

B.4 Motorola Canadian Technical Logistics Center

Motorola Canada Ltd.
8133 Warden Avenue
Markham, Ontario, L6G 1B3
Tel: 1-800-543-3222
Fax: 1-888-331-9872 or 1-905-948-5970

Index

A

- accessories
 - installing
 - dash mount3-1
 - pin configuration3-3
 - pin functions3-2, 3-3
- antenna
 - cable, see Cables, antenna
 - connection2-12
 - diagrams2-12
 - installing2-10
 - mounting2-10

B

- black lead2-8

C

- cables
 - antenna2-3, 2-12
 - connection4-1
 - diagrams2-9, 2-12
 - ignition2-10
 - ignition sense2-10
 - power2-8
- configurations
 - dash mount1-4
- control head1-4

D

- dash mount
 - accessories installations3-1
 - configuration1-4
 - installation2-2
 - radio dimensions1-1, 1-2
 - trunnion2-4, 2-5

E

- emergency footswitch3-4
- emergency pushbutton3-4

F

- footswitch, emergency3-4

H

- horn relay3-5

I

- ignition
 - cable2-10
- installation
 - examples2-1

L

- leads
 - black2-8
- light relay3-5
- locking kit, installing2-6

M

- microphone
 - hang-up clip, standard2-13
- mounting configurations2-3
 - dash1-4, 2-4

O

- ordering replacement partsA-1

P

- parts, ordering replacementA-1
- pin
 - functions3-2, 3-3
 - removal tool2-1
- pin configuration3-3
- pushbutton, emergency3-4

R

- relays
 - horn3-5
 - light3-5
- replacement parts, orderingA-1

S

- speaker
 - connecting3-2, 3-3
 - mounting3-6

T

- tools, required2-1
 - trunnion
 - bracket for speaker3-6
 - dash mount2-4
 - locking kit2-6
 - mounting bracket2-4
 - orientation2-3
 - transmission hump mounting2-4
-

W

wiring diagrams2-2



Motorola Solutions, Inc.
1303 East Algonquin Road
Schaumburg, Illinois 60196 U.S.A.

MOTOROLA, MOTO, MOTOROLA SOLUTIONS and the Stylized M logo are trademarks or registered trademarks of Motorola Trademark Holdings, LLC and are used under license. All other trademarks are the property of their respective owners.
© 2013 Motorola Solutions, Inc. All rights reserved.
July 2013.

www.motorolasolutions.com/mototrbo



68009622001-A